



ZOCON



ZOCON WEIDESLEEP - GRASSLAND HARROW - WIESENSCHLEPPE HERSES DE PRAIRIE - AIREADOR DE PRADERA

5M

6M

8M



Compleet modulair, verzinkt, robuust frame - Completely modular, galvanized, robust frame -
Komplet feuerverzinkt, modular, robuster Rahmen - Châssis complètement galvanisé, modulaire
Construido robusto, modular y enteramente galvanizado



3 Rij - Row - Reihig - Rangées - Hileras

4 Rij - Row - Reihig - Rangées - Hileras



Zware, omkeerbare combimat met U-beugel voor snel verwisselen van net
Heavy, cast-iron elements can be used from both sides with shackle for quick changing of nets
Schwere drehbare Kombi-Netze mit Bogenschäkel mit Verriegelung zum schnellen Wechsel des Netzes
Tapis lourd, réversible avec manilles de manutention pour changement vite et facile du tapis
Una cadena de arrastre reversible con grilletes liras para cambio de cadena rápido



Zeer zware bok & 2 DW cilinders met transportvergrendeling
Linkage Cat. 2 & mechanic blockage of 2 cylinders
Aufhängung Kat. 2 & Verriegelung durch 2 Zylinder
Attelage de triangle cat. 2 & blocage mécanique des 2 vérins
Enganche tripuntal Cat. II & 2 cilindros hidráulicos de doble efecto



Glijsoffen, hoekbeveiliging, extra zware scharnierpunten
Skids, reinforced corners, extra heavy hinges
Gleitschuhe, Eckenschutz, Schaniergelenke sind sehr robust
Pieds glissants, coins renforcés, charnières extra lourdes
Patines, esquinas reforzadas, bisagras extra pesadas



ZOCON GREENKEEPER (ORIGINAL)

6M



8M



12 traps diepte verstelling van de 10mm tanden
 12-Stage depth adjustment of 10mm tines
 12-Stufen Tiefenverstellung der 10mm Zinken
 Réglage du profondeur 12-étages de 10mm dents
 Ajuste de profundidad de 12 etapas de 10mm dientes

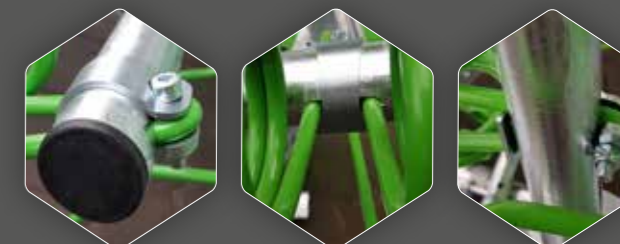

Zeer zware bok Cat. 2 & 2 DW cilinders met transportvergrendeling
 Linkage Cat. 2 & mechanic blockage of 2 cylinders
 Aufhängung Kat. 2 & mechanischen Verriegelung der 2 Zylinder
 Attelage de triangle cat. 2 & blocage mécanique des 2 vérins
 Enganche tripuntal Cat. II & 2 cilindros hidráulicos de doble efecto



3 Rij - Row - Reihig - Rangées - Hileras

10mm Tandem - Tines - Zinken - Dents - Dientes



Glijsloten, hoekbeveiliging, extra zware scharnierpunten
 Skids, reinforced corners, extra heavy hinges
 Gleitschuhe, Eckenschutz, Schaniergelenke sind sehr robust
 Pieds glissants, coins renforcés, charnières extra lourdes
 Patines, esquinas reforzadas, bisagras extra pesadas



OPTIES - OPTIONAL - OPTION - OPTIONNELLE - OPCIONAL

Zaaimachine - Seeder - Sämaschine - Semoir - Sembradora - 150L, 300L, 450L

OPTIES - OPTIONAL - OPTION - OPTIONNELLE - OPCIONAL

Zaaimachine - Seeder - Sämaschine - Semoir - Sembradora - 150L, 300L, 450L



OPTIES - OPTIONAL - OPTION - OPTIONNELLE - OPCIONAL

Extra Glijloffen - Extra Skids - Extra Gleitschuhe - Pieds Glissants Additionnels - Patín Extra

OPTIES - OPTIONAL - OPTION - OPTIONNELLE - OPCIONAL

Voor Zaaimachine - For Seeder - Für Sämaschine - Pour Semoir - Para Sembradora

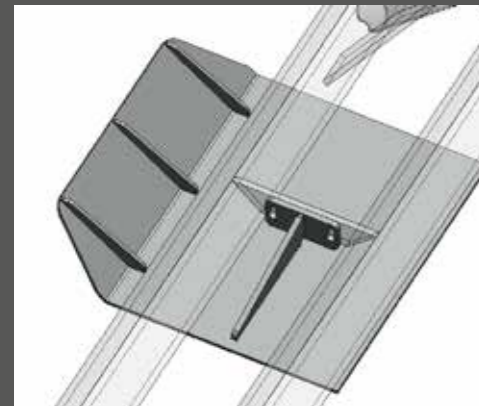
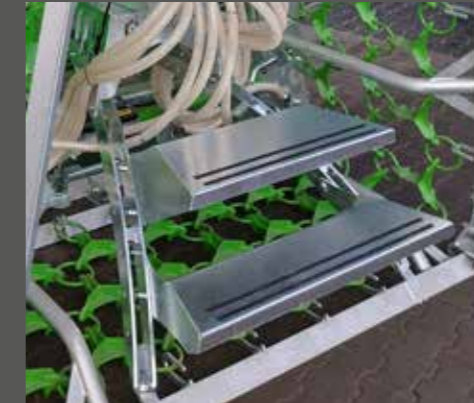
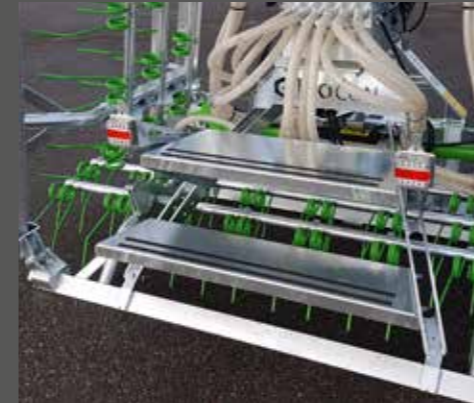
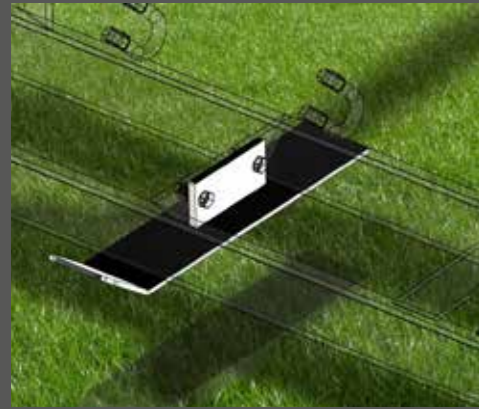

Traptreden te adviseren bij keuze zaaimachine
Stairs to be advised when choosing a seeder
Treppe zu beraten bei der Auswahl der Sämaschine
Escalier à conseiller lors du choix d'un semoir
Escaleras a tener en cuenta al elegir una sembradora

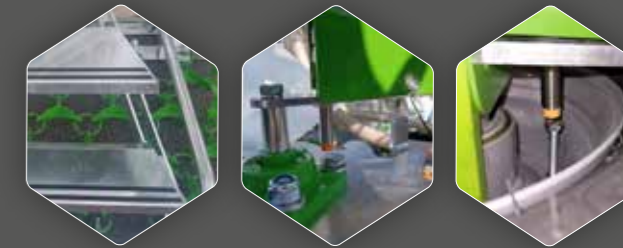

Extra Glijloffen 100mm breed of 500mm breed (max. 3st bij 5m/6m en max. 5st bij 8m)
Extra Skids 100mm wide or 500mm wide (max. 3 pieces for 5m/6m & 5 pieces for 8m)
Extra Gleitschuhe 100mm breit oder 500mm breit (max. 3st für 5m/6m & 5st für 8m)
Pieds Glissants Additionnels 100mm ou 500mm large (max. 3 pièces pour 5m/6m & 5 pièces pour 8m)
Patín extra 100mm o 500mm (máx. 3 piezas para 5m/6m y 5 piezas para 8m)



Sensor met stappenwiel voor zaaimachine
Sensor + Groundwheel for seeder
Sensor für Geschwindigkeit + Bodenrad
Capteur de Vitesse et roue de terre
Sensor de velocidad con una rueda

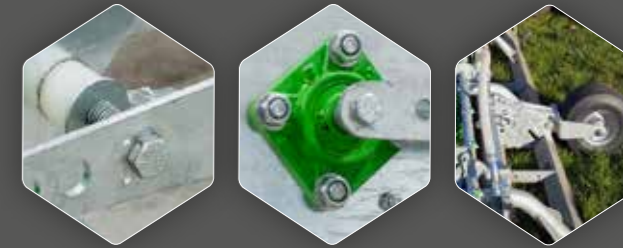

Geleidewielen (Band 15/6.00-6)
Guide wheels (Tire 15/6.00-6)
Stützräder (Reife 15/6.00-6)
Roues additionnel (Roue 15/6.00-6)
Rueda de guía (Ruedo 15/6.00-6)

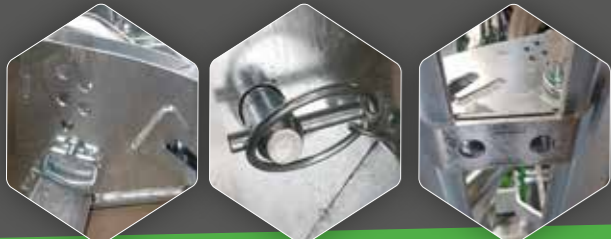
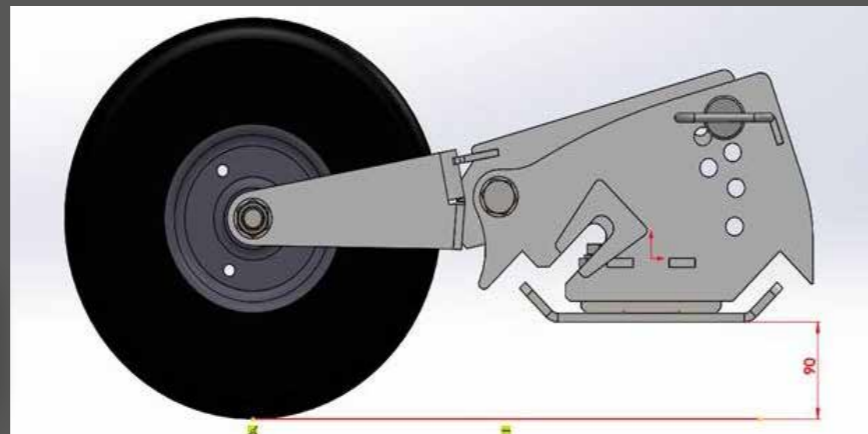

OPTIES - OPTIONAL - OPTION - OPTIONNELLE - OPCIONAL

Frontbok - Frontlinkage - Frontbock - Attelage avant (Front) - Enganche tripuntal Frontal



Dubbele functie: driepuntsbok voor front en achterzijde
 Double function: threepoint linkage for front and rear side
 Doppelfunktion: Dreipunktsbetrieb für Front und Rückseite
 Double fonction: Attelage de triangle pour avant et arrière
 Doble función: Enganche tripuntal para delantera y traserso



OPTIES - OPTIONAL - OPTION - OPTIONNELLE - OPCIONAL



Zaadeg voor Greenkeeper (original)
 Seed Tines for Greenkeeper (original)
 Sä Eggenzinken für Greenkeeper (original)
 Dents à semer pour Greenkeeper (original)
 Cuarto hileras para Greenkeeper (original)

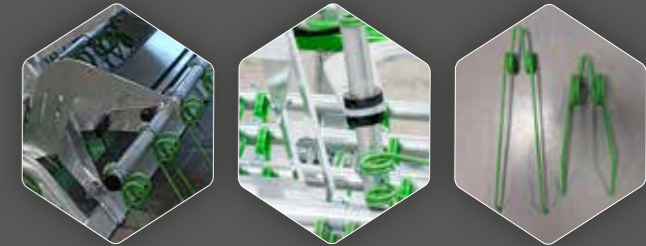

LED Verlichting met breedtemarkering
 Lighting LED with warning Plates
 Beleuchtung LED mit Warntafeln
 Éclairage LED avec marquage largeur
 Iluminación LED con placas de señales



ZOCON GREENKEEPER PLUS

3M

6M

8M



Open achterzijde, modulair en compleet verzinkt
 Frame with open rear side, completely galvanized
 Geöffnete Rückseite, feuerverzinkter modularer Rahmen
 Châssis galvanisé à chaud ouvert arrière
 Marco trasero abierto, modular y enteramente galvanizado



Verstelbare glijloffen voorzijde
 Adjustable skids frontside
 Verstellbare gleitschuhe Front
 Pieds glissants réglables d'avant
 Patinés ajustables delanteras

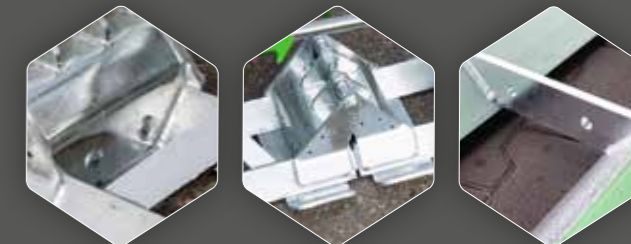

3 Rij - Row - Reihig - Rangées - Hileras

10mm Tandem - Tines - Zinken - Dents - Dientes



Verstelbare glijloffen achterzijde (6m/8m)
 Adjustable skids rear side (6m/8m)
 Verstellbare gleitschuhe Rückseite (6m/8m)
 Pieds glissants réglables arrière (6m/8m)
 Patinés ajustables traseros (6m/8m)



OPTIES - OPTIONAL - OPTION - OPTIONNELLE - OPCIONAL

OPTIES - OPTIONAL - OPTION - OPTIONNELLE - OPCIONAL



Hoogte instelbare geleidewielen voorzijde
 Height adjustable guide wheels front
 Höhenverstellbare Räder Front
 Roues de support réglables en hauteur avant
 Ruedas de guías alturas ajustable delantera



Zaaimachine Z150, Z300, Z450
 Seeder Z150, Z300, Z450
 Sämaschine Z150, Z300, Z450
 Semoir Z150, Z300, Z450
 Sembradora Z150, Z300, Z450



Hoogte instelbare geleidewielen achterzijde
 Height adjustable guide wheels rear
 Höhenverstellbare Räder Rückseite
 Roues de support réglables en hauteur arrière
 Ruedas de guías ajustables trasero



Naast grasland is de PLUS ook zeer geschikt voor bouwland
 In addition to grassland, the PLUS is also very suitable for arable land
 Neben Grassland ist der PLUS auch sehr gut geeignet für Ackerland
 En plus des prairies, il convient également très bien aux terres arables
 Además de pastizales, también es muy adecuado para tierras de cultivo

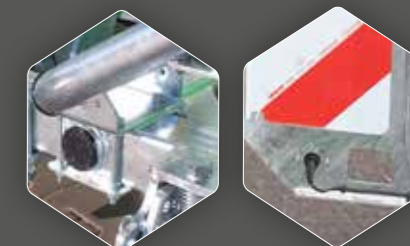

ZOCON ZAAMACHINE - SEEDER - SÄMASCHINE SEMOIR - SEMBRADORA Z150, Z300, Z450



Z150 = 150L



Z300 = 300L



Z450 = 450L



Aantal uitlopen mogelijk 4 t/m 13 - Number of outlets possible 4 til 13 -
Anzahl der Ausgänge möglich 4 bis einschließlich 13 - Nombre de sorties possibles 4 à 13 -
Número de salidas posibles 4 hasta 13



“Basic” bediening met memory, afneembaar en vochtbestendig
“Basic” control box with memory removable and moisture
“Basic” Steuermodul abnehmbar und feuchtigkeitsbeständig
Boitier “Basic” de régulation avec memoire
“Basic” control box desmontable, impermeable y con memoria



Compleet verzinkt frame, witte tank met scharnierbaar deksel
Complete galvanized frame, white transparent hopper with hinged lid
Komplett feuerverzinkt, Weißer Kunststoffbehälter mit Klappdeckel
Cadre galvanisé, réservoir en plastique blanc avec couvercle à charnière
Marco galvanizado y recipiente de plástico blanco con tapa abatible

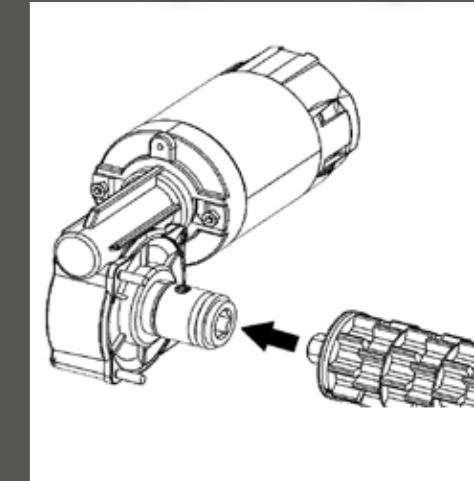

24 standen t.b.v. zaaihoeveelheid, elektrisch aangedreven twin blower
24 positions for sowing rate, electrically driven Twin blower
24 Positionen für die Aussaatmenge, elektrisch angetriebene Doppelgebläse
24 positions pour régler la quantité de semis, ventilateur double électronique
24 posiciones por los cantidades a sembrar, ventilador doble eléctricamente



**SNELWISSELSYSTEMEN - QUICK CHANGE SYSTEMS -
SCHNELLWECHSELSYSTEME - SYSTÈME DE CHANGEMENT RAPIDE
SISTEME DE CAMBIO RÁPIDO**



**Snelwissel mondstuk en zaairol
Quick-Change outputs and seed rotor
Schnellwechsel für Ausgänge und Säwelle
Système de changement rapide de embouts et cannelure
Sistema de cambio rápido de salidas y eje de siembra**



**Snelwisselvoet voor snel uitwisselen tussen machines
Plate for quick-change seeder between different implements
Schnellwechselplatte für Wechsel mehreren Maschinen
Plaque de changement pour monter sur une autre machine
Sistema cambio rápido de Sembradora entre múltiples máq.**

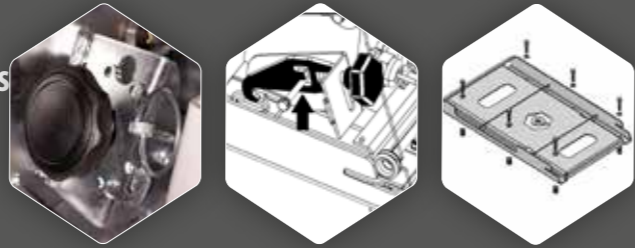

**Geïntegreerde opvangbak voor snelle/nauwkeurige afdraaioproef
Integrated collector for a quick/accurate calibration test
Integrierter behälter für schnellen und genauen Abdrehprobe
Bac intégré pour contrôle rapide et précis de débit
Contenedor integrado para una prueba de calibración rápida/precisa**



**Geïntegreerde opslag voor een extra zaairotor, klemmen etc.
Integrated storage for an extra seed rotor, clamps, etc.
Integrierter platz für extra Säwelle, Materiale, usw.
Bac intégré pour contrôle rapide et précis de débit
Espacio de almacenamiento para cables o ejes de siembra**



**5 traps instelling afdichtrubber
5-stage adjustment rubber seal
5-stufige Einstellung der Gummidichtung
Caoutchouc d'étanchéité à 5 étapes
Configuración de 5 etapas de goma de sellado**

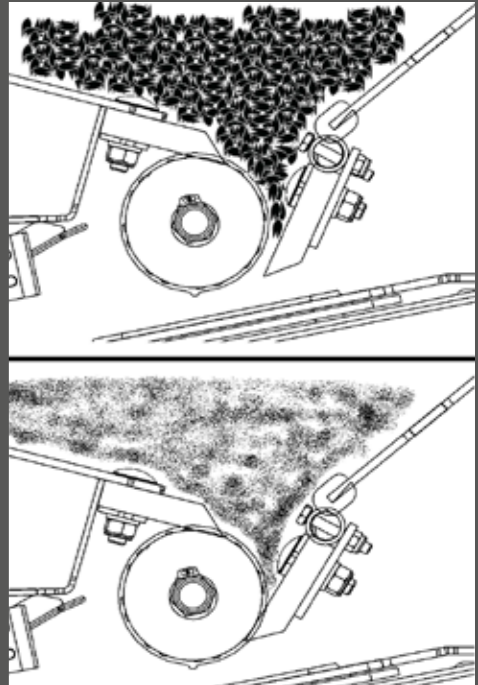

ZAAIROLLEN - SEED ROTORS - SÄWELLE CANNELURES - EJE DE SIEMBRA

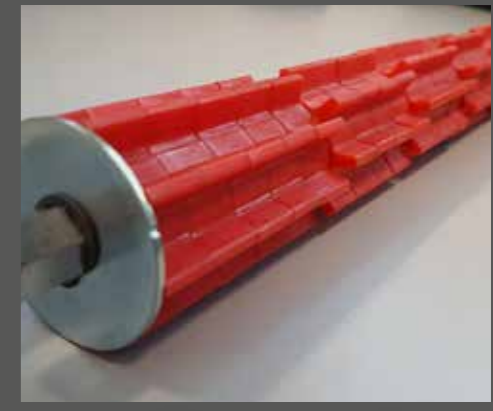
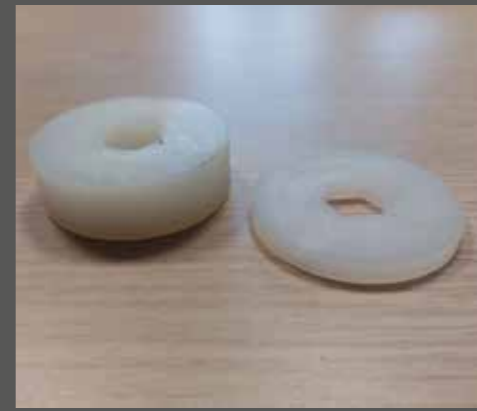
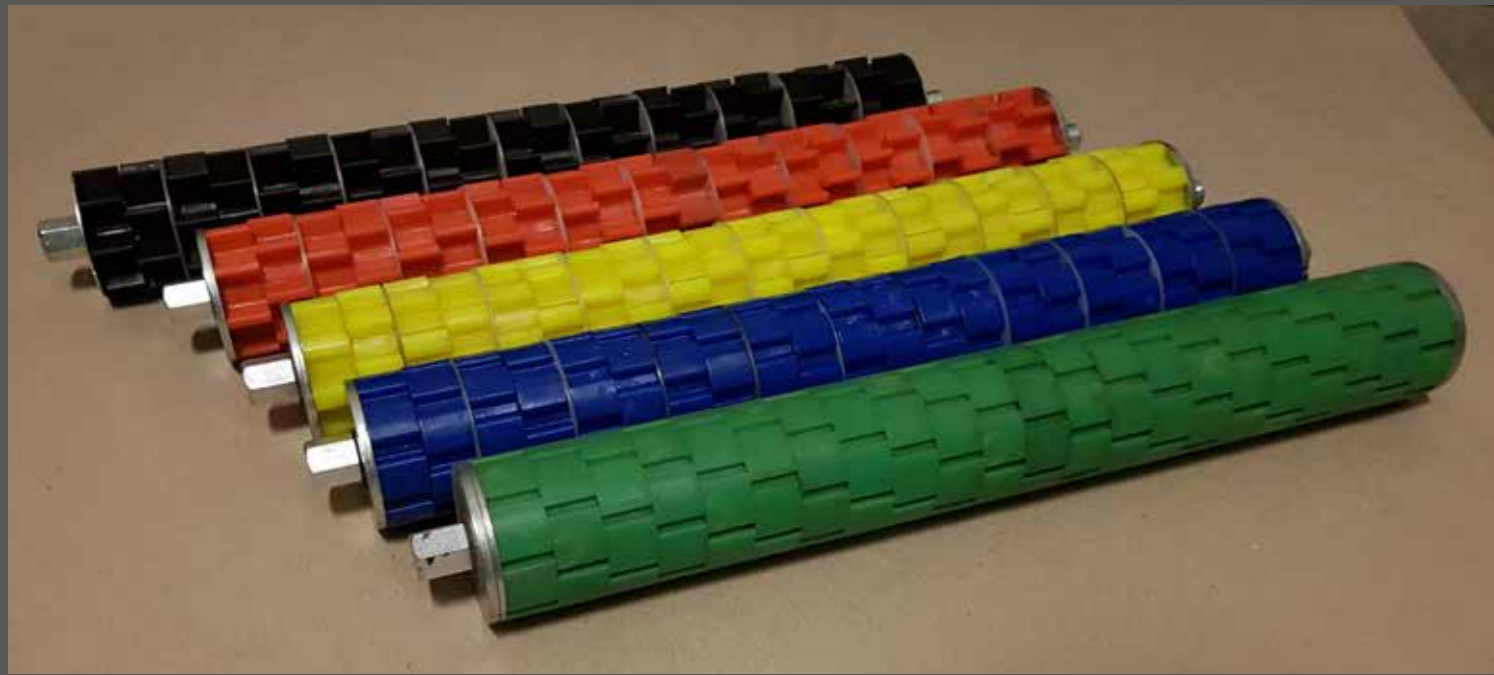

Speciale klantspecifieke zaaïrollen voor verschillende types zaad
 Special customer-made seed rotors for different types of seed
 Spezielle kundenspezifische Säwelle für unterschiedliche Saatgutarten
 Cannelures de semis spéciaux pour différents types de semences
 Ejes de siembra especiales para diferentes tipos de semillas

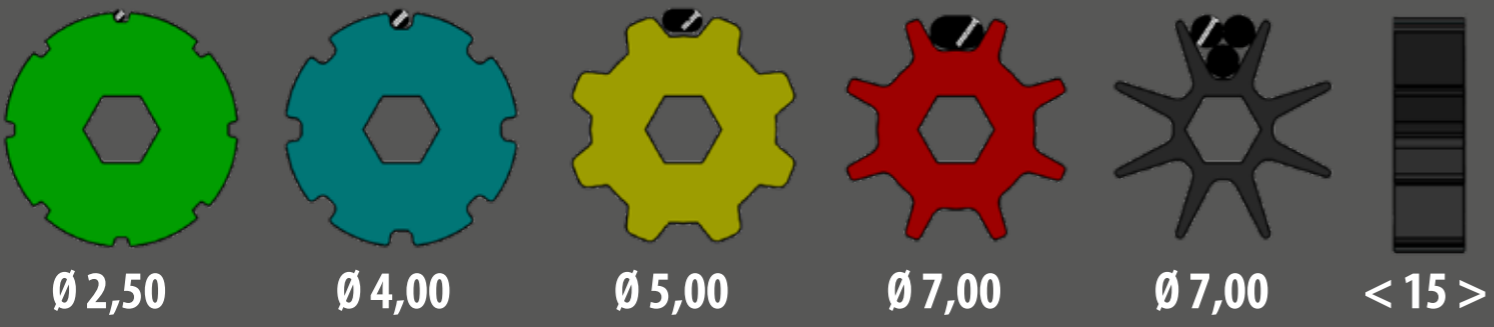
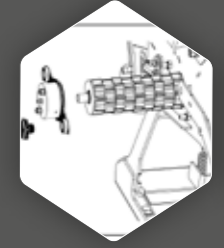

Zocon ketsplaten en buisje voor slang Ø30, Y-splitter
 Zocon deflectors and tube for hose Ø30, Y-splitter
 Zocon Prallteller und Rohr für Schlauch Ø30, Y-splitter
 Zocon déflecteurs et tubes pour tuyau Ø30, Y-séparateur
 Zocon chapas deflectoras y tubos, manguera Ø30, Y-divisor

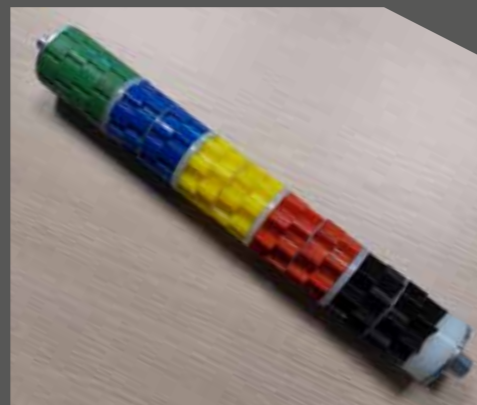

KABELS - CABLES - KABELS - CÂBLES - CABLES

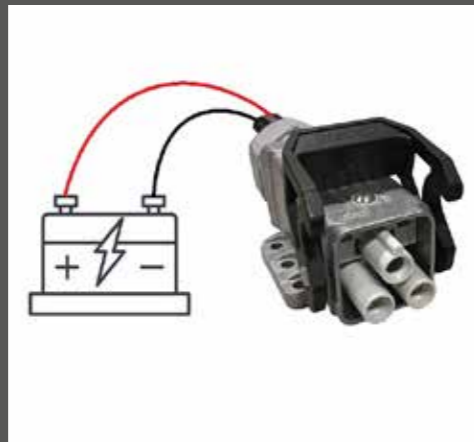

Kabel 5m voor stroomvoorziening direct vanaf accu tractor
 Cable for power supply directly from tractor battery
 Kabel für Stromversorgung direkt von der Traktorbatterie
 Câble d'électricité directement sur l'accu du tracteur
 Cable para alimentación directamente desde la tractorbatería



7 polige signaalstekker of snelheids/hefsensor
 7-pin signal cable ISO or speed/lift sensor
 7-poliger Signalkabel oder Geschwindigkeits-/Hubsensor
 Câble de signal à 7 pôles ou capteur de vitesse/levage
 Cable de señal de 7 polos ISO o sensor de velocidad/elevación





www.zocon.eu